

Ansicht Vorderseite
PP 28 S CE.T.I.E. GME 32.06:2009-06

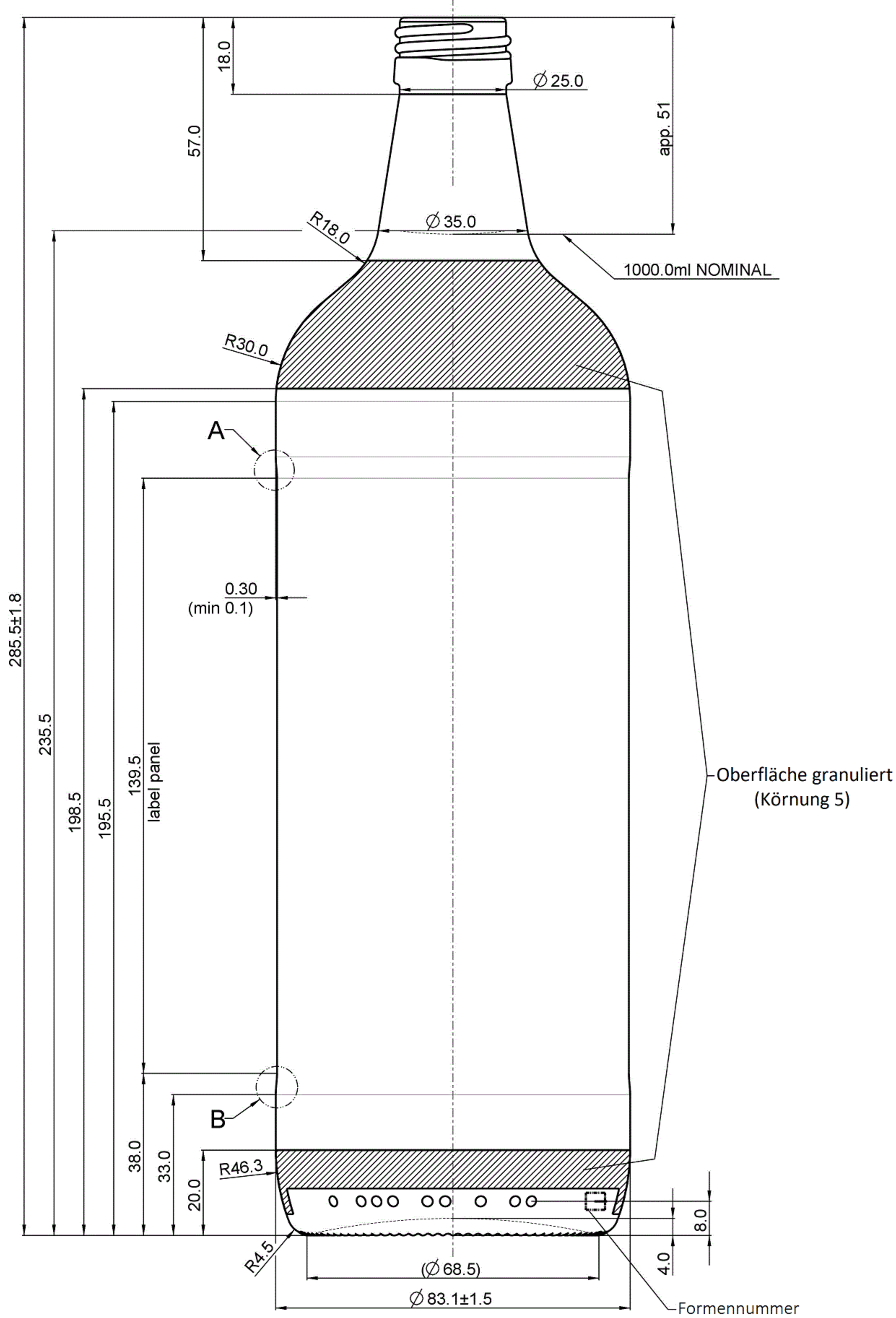

Ansicht Rückseite

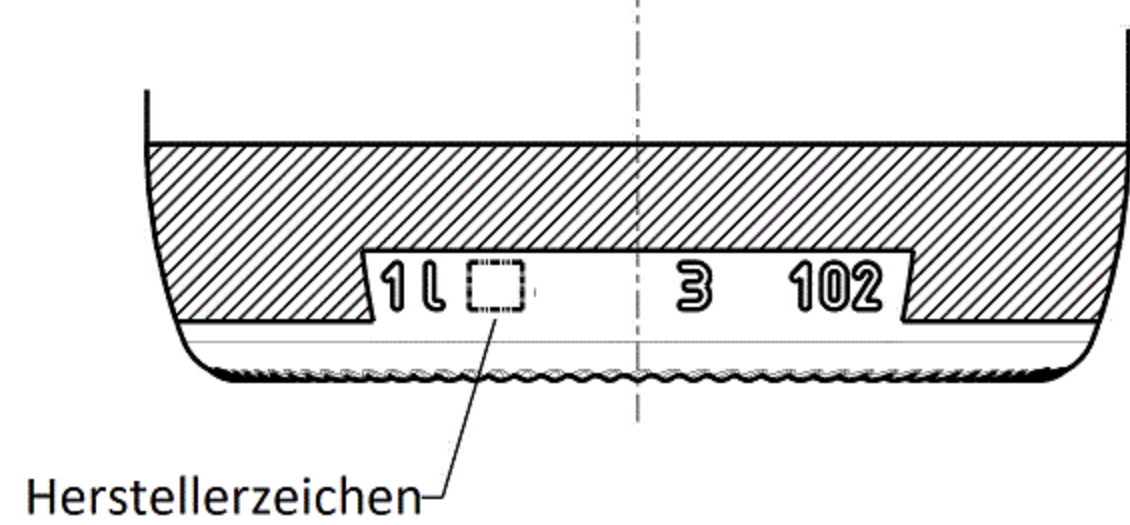

Bodenansicht

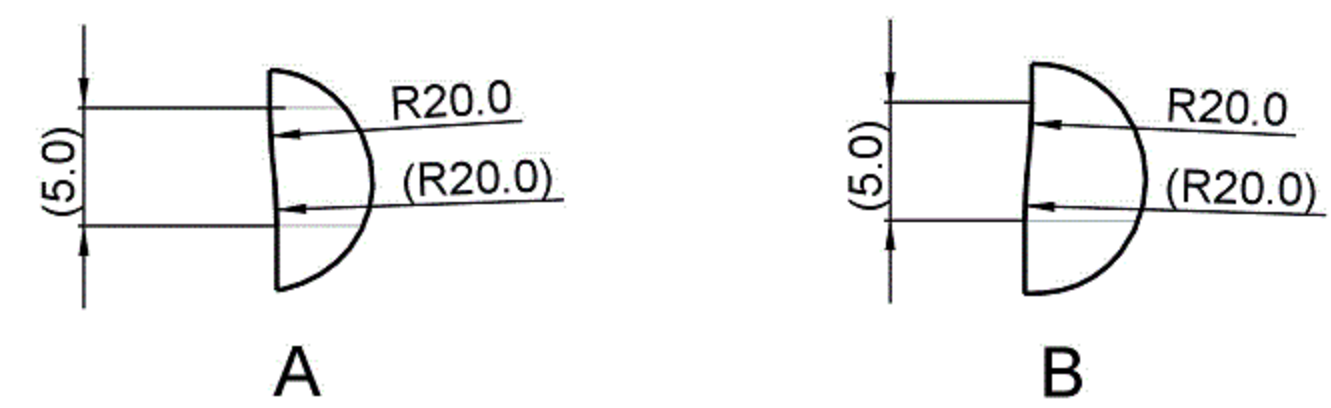
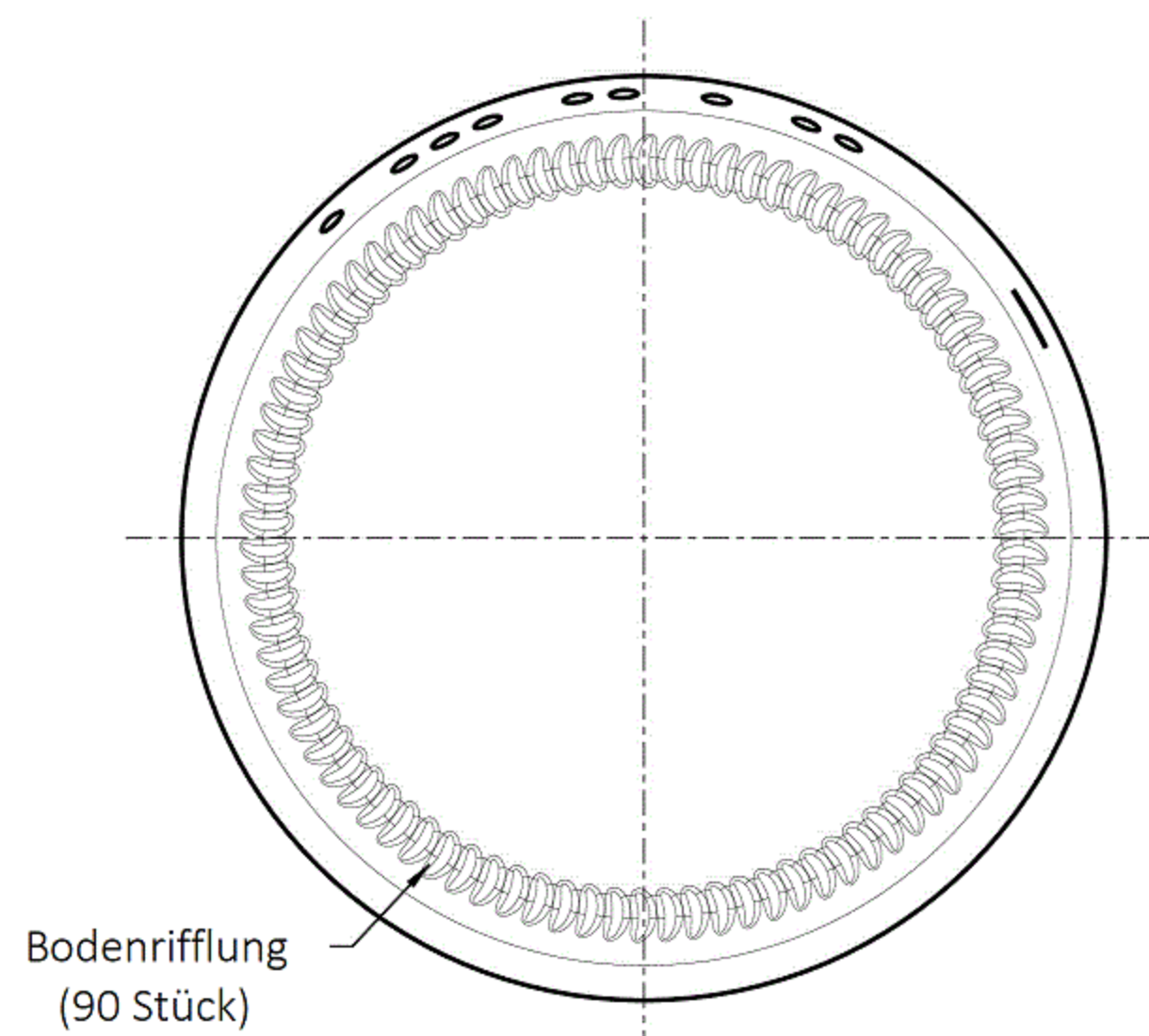

Bezeichnung / Description
1000ml Kurzhals teilgranuliert

Nennvolumen Useful capacity	1000 ml
Randvollvolumen Brimful capacity	1020 ml
Volumentoleranz Tolerance volume	±10 ml (EW) / ± 3,5ml (MW)
Mündung Finish	PP28 S (CETIE . GME 32.06 : 2009-06)
Farbe Color	weiß / flint
Gewicht Weight	ca. 450 g
Thermoschock Thermal shock	max. ΔT 40°
max. Innendruck (1 Min.) max. Internal pressure	ohne / without CO ₂



HILLEBRANDT GLAS

Tietjenstraße 9
12309 Berlin
Germany

+49 (0)30 700 77 61 - 0
+49 (0)30 700 77 61 - 11
kontakt@hillebrandt-glas.de
www.hillebrandt-glas.de